

Ventilation Fans



QTREN Series

Energy efficient solutions in traditional designs.

With their super quiet operation, these bath fans won't call attention to themselves or overpower the design of your bath or powder room. More important, they won't call attention on your electric bill. The QTREN line for energy efficiency was developed for the high-traffic bathroom and for those who seek a fan with a more traditional design. It simply does its job quietly, in every sense of the word.

- Energy Star qualified
- Permanently lubricated motor engineered for continuous operation
- UL listed for use over bathtubs and showers when connected to a GFCI protected branch circuit
- Resilient anti-vibration motor mounts
- Dynamically balanced centrifugal blower wheel for quiet and efficient performance
- Rugged steel housing features mounting ears plus adjustable hanging bars
- 4" round duct connector
- Includes unique spacer (patent pending) for mounting to engineered "I" joists
- Lighted models include 2-18 watt compact fluorescent GU24 type bulbs (4 watt night-light bulb not included)
- Suitable for 2" x 8" constructions

SPECIFICATIONS

MODEL	FUNCTION	CFM AT 0.1" SP*	L/s** AT 0.1" SP	CFM AT 0.25" SP	SONES AT 0.1" SP	POWER RATING	WATTS AT 0.1" SP	SHIPPING WEIGHT (POUNDS)	DUCT SIZE
QTRENO70C	Fan	70	33.0	48	0.8	120/60	28.4	12.0	4"
QTRENO80C	Fan	80	37.8	55	0.8	120/60	28.4	12.0	4"
QTRENO90C	Fan	90	42.5	68	1.0	120/60	29.7	12.0	4"
QTREN110C	Fan	110	51.9	90	1.3	120/60	36.3	12.0	4"
QTRENO70FLC	Fan-Light	70	33.0	58	0.8	120/60	27.0	15.4	4"
QTRENO90FLC	Fan-Light	90	42.5	68	1.0	120/60	29.7	15.4	4"
QTREN110FLC	Fan-Light	110	51.9	90	1.3	120/60	36.3	15.4	4"

* Static pressure.

** Litres per second.

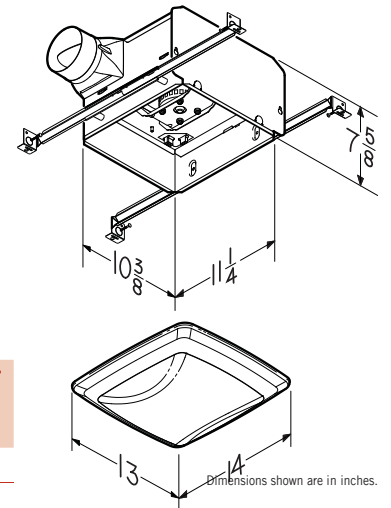

86179C