



## QTRN Series

**Quiet performance and traditional styled grilles that blend with any décor.**

For the bathroom that's not used everyday, you may not be as concerned about energy efficiency. QTRN fan and fan-light models are still among the quietest products in their category and the lighted models feature soft incandescent lighting.

- Permanently lubricated motor engineered for continuous operation
- Dynamically balanced centrifugal blower wheel for quiet and efficient performance
- Rugged steel housing with sturdy, easy, four-point mounting directly to joist
- cUL and UL listed for use over bathtubs and showers when connected to a GFCI protected branch circuit
- Housing features mounting ears plus adjustable hanger bars
- Lighted models feature bright 100-watt lighting and 4-watt night-light (bulbs not included)
- Suitable for 2" x 8" constructions
- 4" round duct connector
- Available in lighted and non-lighted models

### SPECIFICATIONS

MODEL	FUNCTION	CFM AT 0.1" SP*	L/s** AT 0.1" SP	CFM AT 0.25" SP	SONES AT 0.1" SP	POWER RATING	AMPS	SHIPPING WEIGHT (POUNDS)	DUCT SIZE
QTRN090C	Fan	90	42.5	68	1.0	120/60	0.9	12.4	4"
QTRN110C	Fan	110	51.9	99	1.5	120/60	0.9	12.4	4"
QTRN090LC	Fan-Light	90	42.5	68	1.0	120/60	1.8	13.8	4"
QTRN110LC	Fan-Light	110	51.9	99	1.5	120/60	1.8	13.8	4"

\* Static pressure

\*\* Litres per second

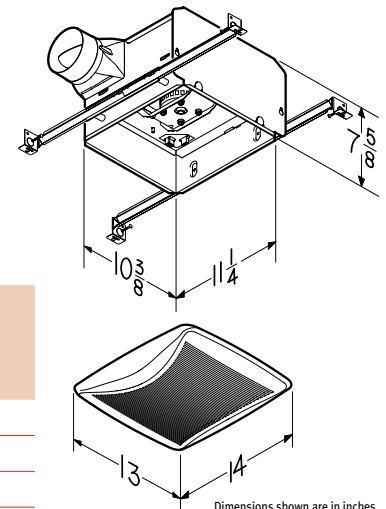

Dimensions shown are in inches.



87441B