



QuietTest Series

Powerful air movement with very quiet operation.

QuietTest fans provide powerful, quiet ventilation for large bathrooms, recreation rooms, offices and conference rooms up to 375 sq. ft.

- Rounded, low-profile white polymeric grilles add distinction to your room
- Motor and dynamically balanced twin blowers are rated for continuous duty
- Brown enamel steel housing is lined with sound-deadening foam for quiet operation
- Housing Dimension: 14-1/4" x 10" x 9"
- Vents horizontally or vertically with 3-1/4" x 10" duct
- Suitable for use with solid state speed control (sold separately)
- Includes prewired outlet boxes with plug-in receptacles for easy installation

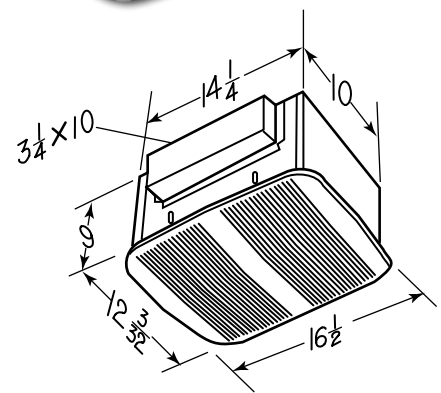

Dimensions shown are in inches.

SPECIFICATIONS

MODEL	CFM AT 0.1" SP*	L/s** AT 0.1" SP	SONES AT 0.1" SP	POWER RATING	AMPS	SHIPPING WEIGHT (POUNDS)	DUCT SIZE
QT200	200	94.0	2.0	120/60	1.0	17.0	3-1/4" x 10"
QT300	300	142.0	4.5	120/60	2.5	20.0	3-1/4" x 10"

* Static pressure
** Litres per second



87539B